

Lugger Rules

1. Fareham Luggers must be built and sailed in the spirit of one design racing.
2. All freedom of build will be allowed within the bounds of the measurement and FSMBC rules.
3. All hulls must be made from the certified moulds held by FSMBC or their authorised agent. These moulds include hull, mast step box, dagger board case, forward buoyancy tank and aft buoyancy tank.
4. All sails must be made by FSMBC authorised agent and to the specification approved by FSMBC. Sail numbers will be allocated by FSMBC.
5. The dagger board must be made of plywood and not protrude more than 22" below the hull.
6. Rudder stocks must be of wooden construction with a plywood rudder blade of not more than 0.5" thick. Fixed or lifting blades are permitted.
7. The rig must be a standing lug and the gaff should always be wholly set on the port side of the mast.
8. The mast must be made of wood or aluminium construction of not more than 2.25" x 2.25" in section.
9. The maximum length of the mast is set by the distance from lowest inside position of the hull, adjacent to the mast support tube to the top of the main halyard pulley bearing surface at the top part of the mast and must not exceed 9' 6". The mast can extend beyond the main halyard pulley by a maximum of 12".
10. The gaff must be made of wood or aluminium and not exceed 8' 10" in length and generally not more than 2" x 2" in section. The gaff may be additionally stiffened by the use of a single wire span or wooden stiffeners providing that the total side area to the gaff presented to the wind does not exceed 1.75 sq. ft. The main halyard must be attached to the gaff at a point between 20"-28" from the forward lower end of the gaff.
11. The boom must be of wood or aluminium construction and not exceed 7' 7" in length from the back of the mast and not more than 1.75" x 1.75" in section. A kicking strap may be attached to the boom at a point not exceeding 18" from the rear face of the mast. The boom may be suitably reinforced at the kicking strap attachment point.
12. The boom may be set to the port side of the mast.
13. A lateral support or thwart, parallel with the transom, must be fitted between the top of dagger board case and the hull side at the same height. Support ends can be shaped/extended to reach existing hull side mounts.
14. The rear face of the mast box shall be 6' 11" +/- 0.5" measured from the inside of the transom at the top of the buoyancy tank.
15. The rear face of the dagger board box shall be 4'3.5" +/- 0.5" measured from the inside of the transom on top of the buoyancy tank.
16. The running rigging may be used as a forestay without any purchase and must be cleated off. No standing rigging is permitted.
17. Additional seating and flexible buoyancy may be added provided it does not stiffen the hull.
18. No part of the torso shall protrude outside the boat.
19. Fareham Luggers must carry a paddle, life jacket or buoyancy aid, bailer and a permanently attached painter of 6' minimum length.
20. Fareham Luggers berthed on the Lugger pontoon must be equipped with either a waterproof cover or a drain plug.
21. An optional canvas or similar cover may be used on the bow section to prevent 'submarining'
22. Alterations to these rules must be supported by 75% of Lugger owners who are members of FSMBC attending an official FSMBC meeting.

Note: Lugger names should preferably include the letter 'F' and 'L'.

All dimensions in Ft/inches
Not to scale

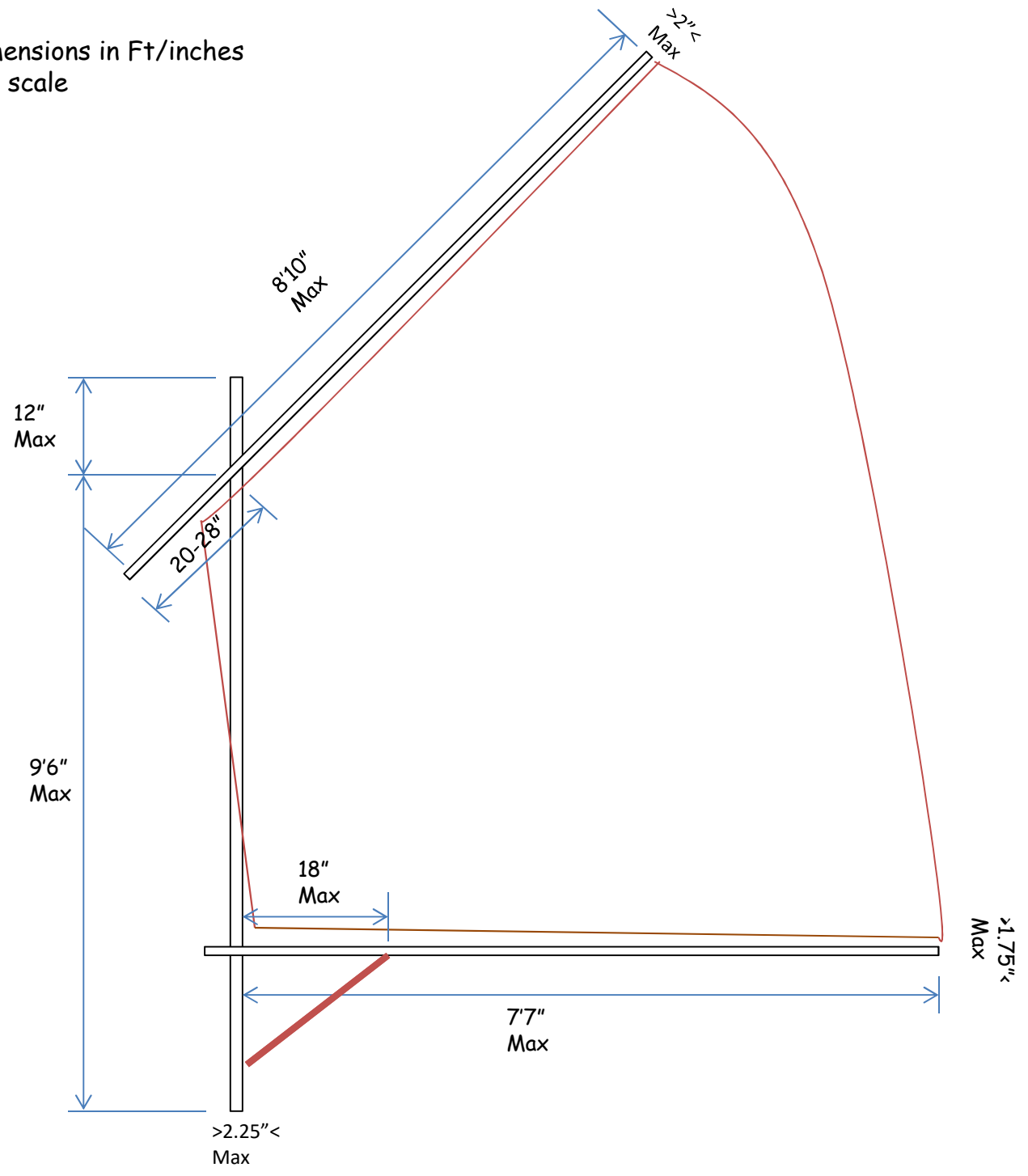

All dimensions in Ft/inches
Not to scale

